

DETAIL "B"

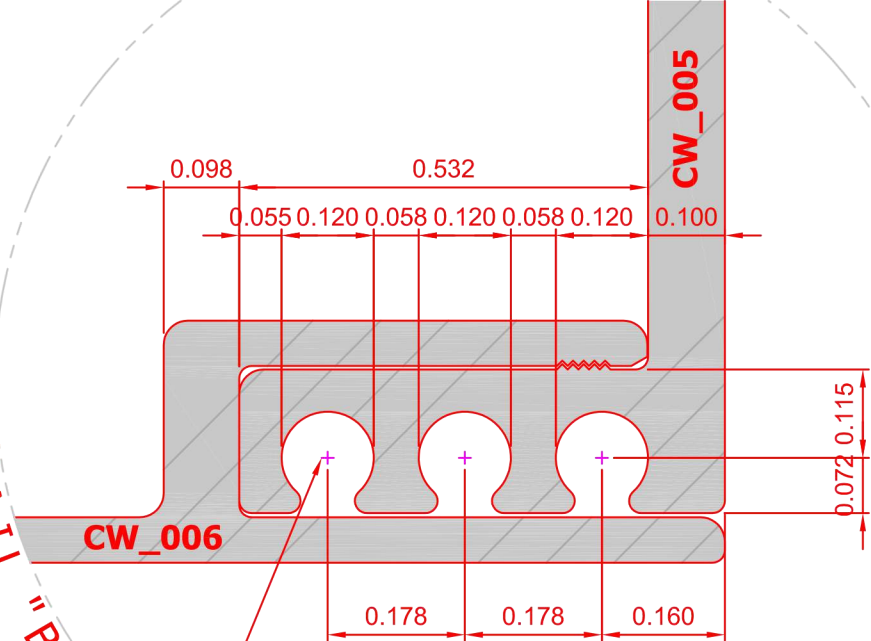

SCREW REGLET (BOSS)  
FOR #8 TEK FASTENERS  
(3) TYPICAL

- 6063-T52 ALUMINUM ALLOY
- UNSPECIFIED RADIUS: 0.016"
- UNSPECIFIED WALL THICKNESS: 0.050"
- MATES WITH: CW\_005 POCKET
- FINISH: PAINT ALL EXPOSED SURFACES (TYP.)  
MILL FINISH OR WHITE
- ALUMINUM ASSOCIATION STANDARD  
TOLERANCES APPLY UNLESS NOTED OTHERWISE.

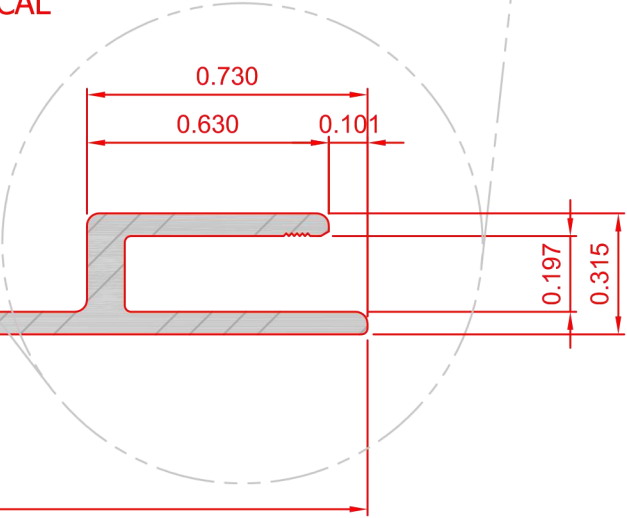

SCREW REGLET (BOSS)  
FOR #8 TEK FASTENERS

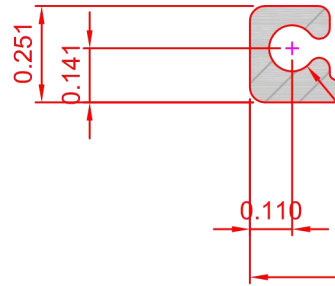

3.154



**CW\_006 CLOSURE  
(MATES WITH CW\_005 POCKET)**

2216 S. INDUSTRIAL HWY.  
ANN ARBOR, MI 48104  
Ph:734.769.5100 Ph:888.996.3697 Fx:734.769.5614

SCALE: 2' = 1'

**CW\_006**